



## **Harrison Hydra-Gen®**

Hydraulic Driven AC Generator System

### **Operation and Installation Guide**

For Harrison Hydraulic Solutions Model(s):

**10.0 MPC**

**15.0 MPC**

**20.0 MPC**

**30.0 MPC**

(3-3-16) - Spec. M

From serial number \_\_\_\_\_ and above

---

*For technical assistance contact:*

Harrison Hydra-Gen, Ltd  
14233 West Rd.  
Houston, Texas 77041

(281) 807-4420 Ph.  
(800) 723-3334 Toll  
(281) 807-4815 Fax

[www.harrisonhydragen.com](http://www.harrisonhydragen.com)

# WARRANTY REGISTRATION CARD

Keep top section for your permanent records.

<b>DATE OF PURCHASE</b>	
<b>GENERATOR MODEL</b>	
<b>SERIAL NUMBER</b>	
<b>PUMP MODEL NUMBER</b>	
<b>SERIAL NUMBER</b>	
<b>WHERE PURCHASED</b>	
<b>ADDRESS</b>	
<b>CITY, STATE, ZIP</b>	



IMPORTANT: A completed warranty registration card (form no. WR-1 below) is required for the fulfillment of any warranty service. Please return this section immediately to ensure your service is not denied or delayed pending proof of purchase information verification.

## WARRANTY REGISTRATION CARD

FORM NO. WR-1

**COMPANY NAME:** \_\_\_\_\_

**ADDRESS:** \_\_\_\_\_

**CITY:** \_\_\_\_\_ **STATE:** \_\_\_\_\_ **ZIP:** \_\_\_\_\_

**CONTACT:** \_\_\_\_\_ **PHONE NO.:** \_\_\_\_\_

**GENERATOR MODEL NO.:** \_\_\_\_\_ **SERIAL NO.:** \_\_\_\_\_

**PUMP MODEL NO.:** \_\_\_\_\_ **SERIAL NO.:** \_\_\_\_\_

**WHERE PURCHASED:** \_\_\_\_\_

Please cut card along  
dotted line, fold, and secure  
with tape before mailing.

CUT HERE



**Harrison Hydra-Gen Ltd.  
14233 West Rd.  
Houston, TX 77041**

FOLD HERE

Place  
Stamp  
Here

# TABLE OF CONTENTS

<b>Warranty Registration Card</b> .....	<b>ii</b>
<b>Table of Contents</b> .....	<b>iv</b>
<b>Table of Figures</b> .....	<b>v</b>
<b>Safety Precautions</b> .....	<b>1</b>
General Safety.....	1
Electrical Shock .....	1
Moving Parts.....	2
Hydraulic Fluid Under Pressure .....	2
Clean Unit and Surrounding Area.....	2
<b>Introduction</b> .....	<b>3</b>
About This Manual.....	3
Parts & Service .....	3
System Overview .....	3
<b>MPC Generator Ordering Code</b> .....	<b>4</b>
<b>Hydraulic Pump Ordering Code</b> .....	<b>5</b>
<b>Specifications</b> .....	<b>6</b>
Tray Unit Dimensions and Weights (Without The Reservoir) .....	6
Alternator Detail .....	6
Hydraulic System .....	6
Drive Motor.....	6
Dimension Drawings.....	7
Hydraulic Pump Information .....	10
80cc Kawasaki Pump .....	10
<b>Installation Guide</b> .....	<b>11</b>
Installation Cleanliness.....	11
Hydraulic Oil Requirements.....	11
Hydraulic Pump Mounting .....	12
Generator Tray Mounting and Airflow.....	15
Hydraulic Reservoir Remote Mounting.....	16
Hydraulic Connections .....	16
Hose Specifications.....	16
Plumbing Diagrams.....	18
Hydraulic Circuit Diagram.....	19
Display Meter Mounting .....	20
Electrical Connections.....	20
Soft Start Solenoid Wiring.....	21
Electrical Circuit Diagram .....	22
<b>Operator's Guide</b> .....	<b>23</b>
Before Starting .....	23
Fill and Bleed Sequence.....	23
Frequency Adjustment .....	24
Normal Operation .....	25
Display Module .....	26
<b>Maintenance</b> .....	<b>27</b>
<b>WEEKLY INSPECTION LOG</b> .....	<b>28</b>
Date .....	28

Hour Meter Reading.....	28
oil level and clean.....	28
hoses leaks condition.....	28
filler / breather clean .....	28
cooler clean.....	28
fan operating.....	28
Accessories.....	29
Generator Display Meter Kit.....	29

## TABLE OF FIGURES

Figure 1: Generator Tray Dimension Drawing (MPC 10-20KW) .....	7
Figure 2: Generator Tray Dimension Drawing (MPC 30KW) .....	8
Figure 3: Reservoir Dimension Drawing .....	9
Figure 4: Kawasaki Pump Dimension.....	10
Figure 5: Air Gun Projectile Cleaner .....	11
Figure 6: Hydraulic Fluid Selection Graph .....	11
Figure 7: Pump Mounting L-Bracket Front View.....	13
Figure 8: Pump Mounting L-Bracket Rear View .....	13
Figure 9: Pump Case Drain Orientation .....	14
Figure 10: Generator Airflow .....	15
Figure 11: Attached Reservoir .....	18
Figure 12: Detached Reservoir.....	18
Figure 13: Hydraulic Circuit Diagram with Kawasaki 80cc Pump .....	19
Figure 14: Display Meter Cutout Dimension .....	20
Figure 15: Display Meter .....	20
Figure 16: Solenoid DIN Connector Connection.....	21
Figure 17: 10-20KW MPC Electrical Circuit Diagram for 120/240 1ph.....	22
Figure 18: 30KW MPC Electrical Circuit Diagram for 120/240 1ph .....	22
Figure 19: Hydraulic Fluid Reservoir .....	23
Figure 20: Kawasaki Pump Control.....	24
Figure 21: Display Meter Module .....	26
Figure 22: Display Mode Button .....	26

# SAFETY PRECAUTIONS

## **WARNING!**

THIS SYMBOL WARNS OF IMMEDIATE HAZARDS OR UNSAFE PRACTICES WHICH WILL RESULT IN SEVERE PERSONAL INJURY OR DEATH.

## **CAUTION!**

THIS SYMBOL REFERS TO A HAZARD OR UNSAFE PRACTICE, WHICH CAN RESULT IN PERSONAL INJURY OR PRODUCT OR PROPERTY DAMAGE.

## **WARNING!**

DO NOT OPERATE THE GENERATOR IF THE VEHICLE HAS BEEN DRIVEN THROUGH HIGH WATER OR SUSPECTED WATER HAS ENTERED THE GENERATOR.

## **WARNING!**

DO NOT SET OPERATING FREQUENCY ABOVE 63 HZ. THE GENERATOR AND ELECTRICAL EQUIPEMENTS CAN BE SEVERELY DAMAGED IF OPERATING FREQUENY IS SET ABOVE 63 HZ.

## **WARNING!**

WITH THE NEW 2007 EMISSIONS, ENGINE EXHAUSTS ARE OPERATING HOTTER. IF OIL COMES IN CONTACT WITH THE EXHAUST, A FIRE COULD OCCUR.

## GENERAL SAFETY

- Electrical equipment and moving parts present potential hazards that may result in serious personal injury. Take care in following these recommended procedures.
- Do not work on this equipment when mentally or physically fatigued.
- Always wear safety glasses.

## ELECTRICAL SHOCK

- Disengage power before moving protective shields or touching electrical equipment.
- Use rubber insulating mats placed on dry wood platforms over floors that are metal or concrete.
- Do not wear damp clothing (including wet shoes) or allow skin surfaces to be damp when handling electrical equipment.
- Jewelry is a good conductor of electricity and therefore should be removed when working on electrical equipment.
- Use extreme caution when working on electrical components. High voltages cause injury or death.
- Generator installation and operation must comply with all applicable local, state, and federal codes and regulations.
- Have all electrical installations performed by a qualified licensed electrician.

### MOVING PARTS

- Avoid moving parts when working on the unit.
- Do not wear loose clothing when working around rotating components.
- Make sure all the nuts and bolts are secure.
- Keep power shields and guards in position.
- If adjustments must be made while the unit is running, use extreme caution around rotating and/or hot components.

### HYDRAULIC FLUID UNDER PRESSURE

- Hydraulic fluid can penetrate the skin, which can result in possible blood poisoning.
- Always shut down the primary engine driving the hydraulic pump before loosening or tightening any fittings.

### CLEAN UNIT AND SURROUNDING AREA

- Keep the unit and surrounding area clean.
- Remove all accumulated grease and oil from the unit. **Do not** store anything in the generator compartment. Both can cause generator system problems (overheating, noise, and vibration), eventual generator damage, and/or potential fire hazards.

# INTRODUCTION

## ABOUT THIS MANUAL

This manual covers the specifications, installation, operation, and maintenance of your Harrison Hydra-Gen hydraulic generator.

## PARTS & SERVICE

To obtain parts or service, please have your **model and serial number** ready and contact us toll free at 1-800-723-3334. Outside of the United States, please call 1-281-807-4420. You can also reach us via fax at 1-281-807-4815. Our office hours are Monday through Friday between 8:00 AM and 5:00 PM Central Standard Time.

Alternately, you may access product information online at [www.harrisonhydragen.com](http://www.harrisonhydragen.com) and obtain support via [customerservice@harrisonhydragen.com](mailto:customerservice@harrisonhydragen.com).

## SYSTEM OVERVIEW

Harrison Hydra-Gen hydraulic generators are comprised of several components. A general hydraulic and electrical component overview for our generator is described below.

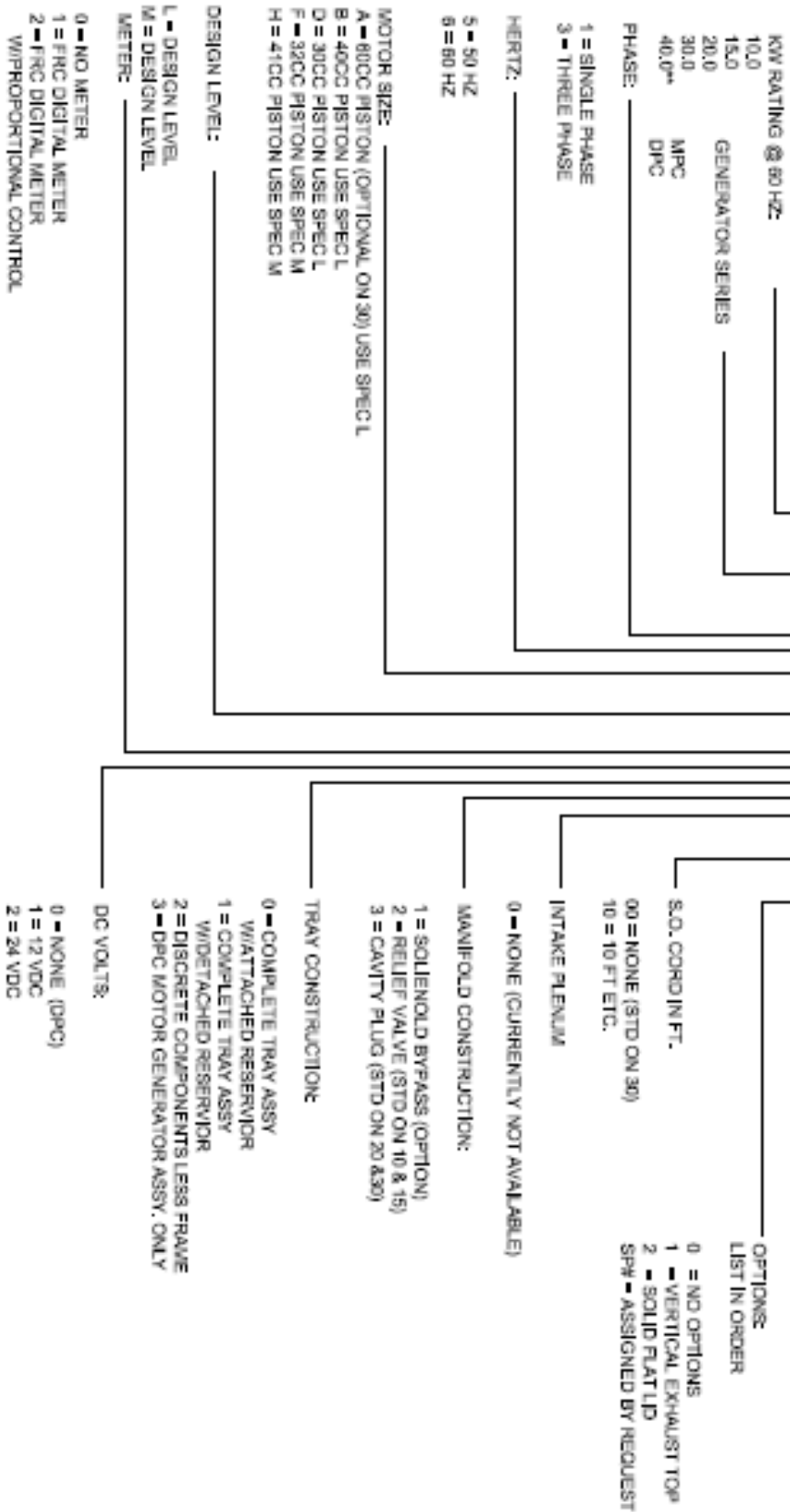
- **Hydraulic Pump:** The hydraulic pump sends hydraulic fluid (oil) to the motor at a constant flow under varying engine speeds.
- **Motor:** The hydraulic motor drives the alternator.
- **Alternator:** An AC brushless revolving field alternator provides regulated AC voltage and is available in single or 3 phase.
- **Heat Exchanger:** When the oil leaves the motor it is cooled in an oil-to-air heat exchanger before it is returned to the reservoir.
- **Hydraulic Reservoir:** The hydraulic oil reservoir is equipped with an oil filter, oil level sight glass, oil temperature gauge, oil filter and breather cap.
- **Display:** The generator can also be equipped with a display meter which displays output voltage, frequency, current, oil temperature, and unit running time.



# MPC GENERATOR ORDERING CODE

## MPC GENERATOR MODEL NUMBER

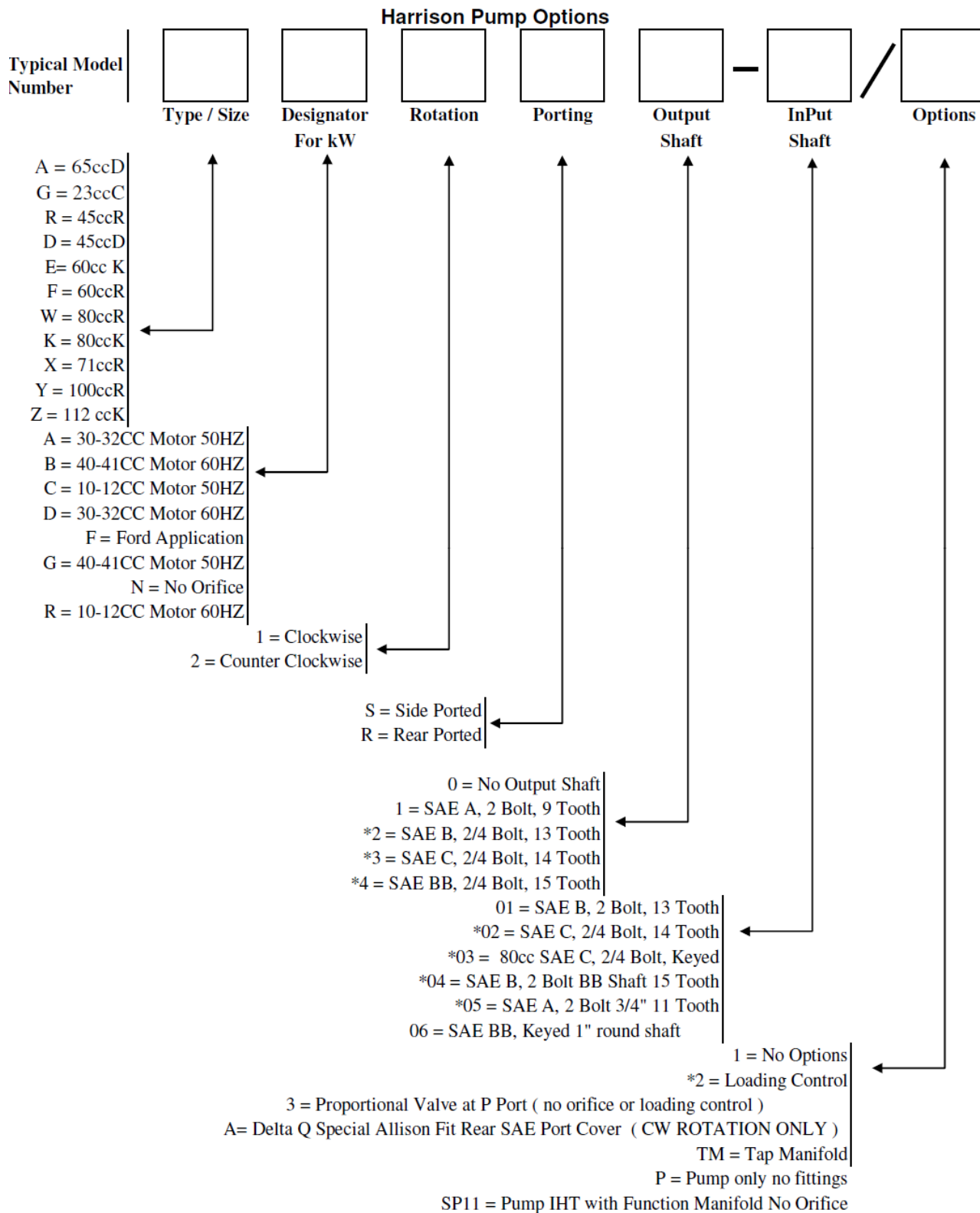
10.0MPC-16F/M-11020/10/0



\*\* 40.0KW AVAILABLE AS DPC ONLY DESIGN LEVEL L

# HYDRAULIC PUMP ORDERING CODE

## PUMP DESIGNATION WORKSHEET



# SPECIFICATIONS

## TRAY UNIT DIMENSIONS AND WEIGHTS (WITHOUT THE RESERVOIR)

	10.0 KW	15.0 KW	20.0 KW	30.0 KW	RESERVOIR
Height	19"	19"	19"	20"	14.0"
Width	29"	29"	29"	35"	6"
Length	23"	23"	23"	24"	21.25
Weight	367 lbs	431 lbs	448 lbs	560 lbs	24 lbs
Max KW	10.0	15.0	20.0	30.0	
Amps @ 120V	80	125	167	250	
Amps @ 240V	40	63	83	125	
Power Required	24 hp	34 hp	48 hp	64 hp	
Max System Pressure	2500 psi	3500 psi	5000 psi	5200 psi	
Flow Rate Approx.	15 gpm	15 gpm	15 gpm	20 gpm	

**Table 1: Tray Unit Dimensions and Weights**

## ALTERNATOR DETAIL

**Design:** Brushless revolving field, four pole, and 1800RPM for 60Hz operation.  
**Rating:** See nameplate for individual unit rating.  
**Regulation:** ± 1% Voltage regulation from nameplate rating.  
**Waveform:** Harmonic distortion is limited to just 4 %  
**Insulation:** Class H, 200° C, Slot Insulation, Varnish, Additional Marine Coating.  
**Power Factor, Pf:** 1.0 (unity) for single phase units, .8 Pf for 3 phase

## HYDRAULIC SYSTEM

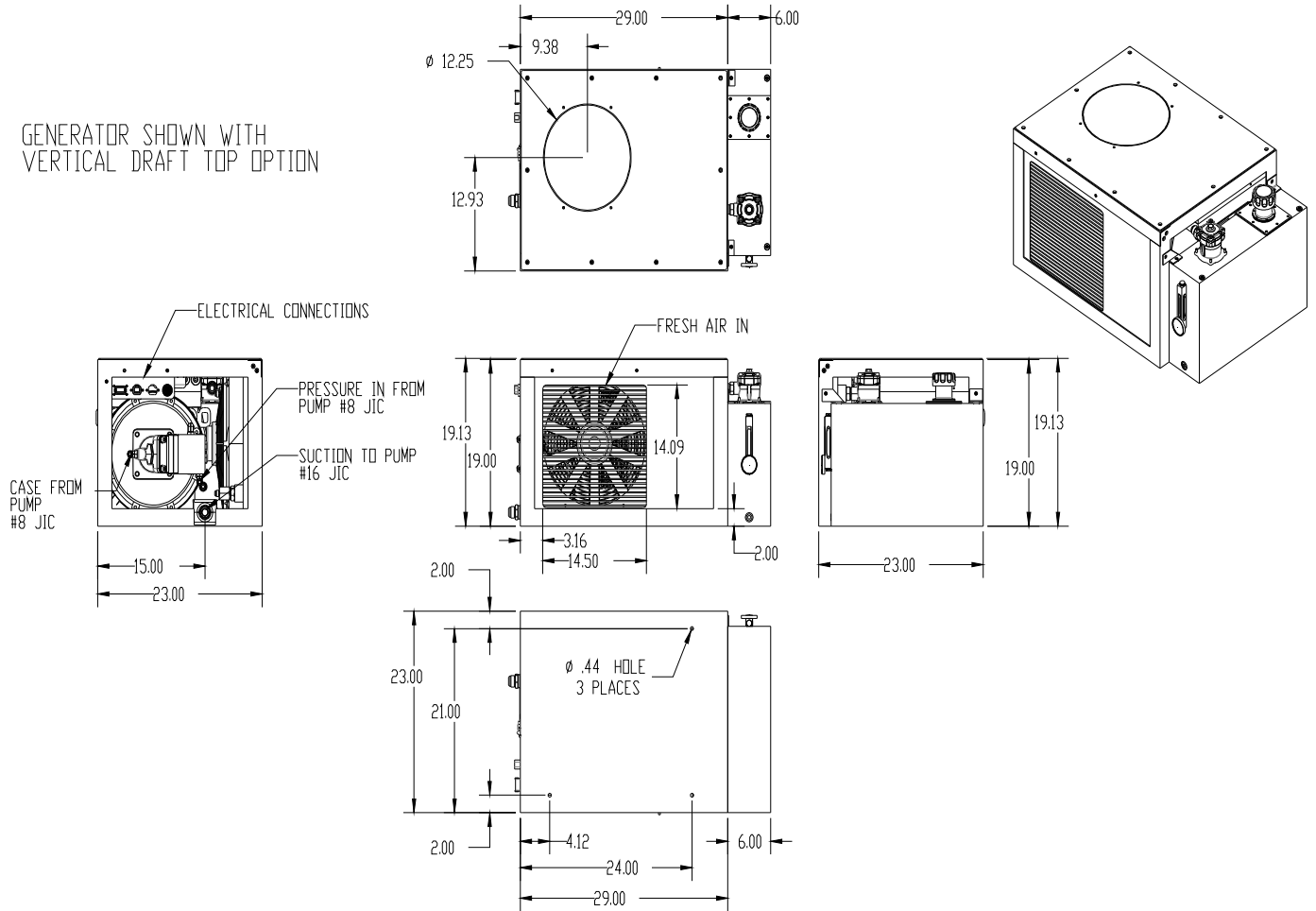
**Type of oil:** Use only premium hydraulic fluid with anti wear, anti foam, and anti rust additives. Optimum operating viscosity is 80-170 SUS. Viscosity should never exceed 4,600 SUS at the coldest startup temperature, and should never be less than 60 SUS at 180°F.  
**Capacity:** The reservoir should contain a minimum of 7.0 gallons (U.S.) of hydraulic oil.

## DRIVE MOTOR

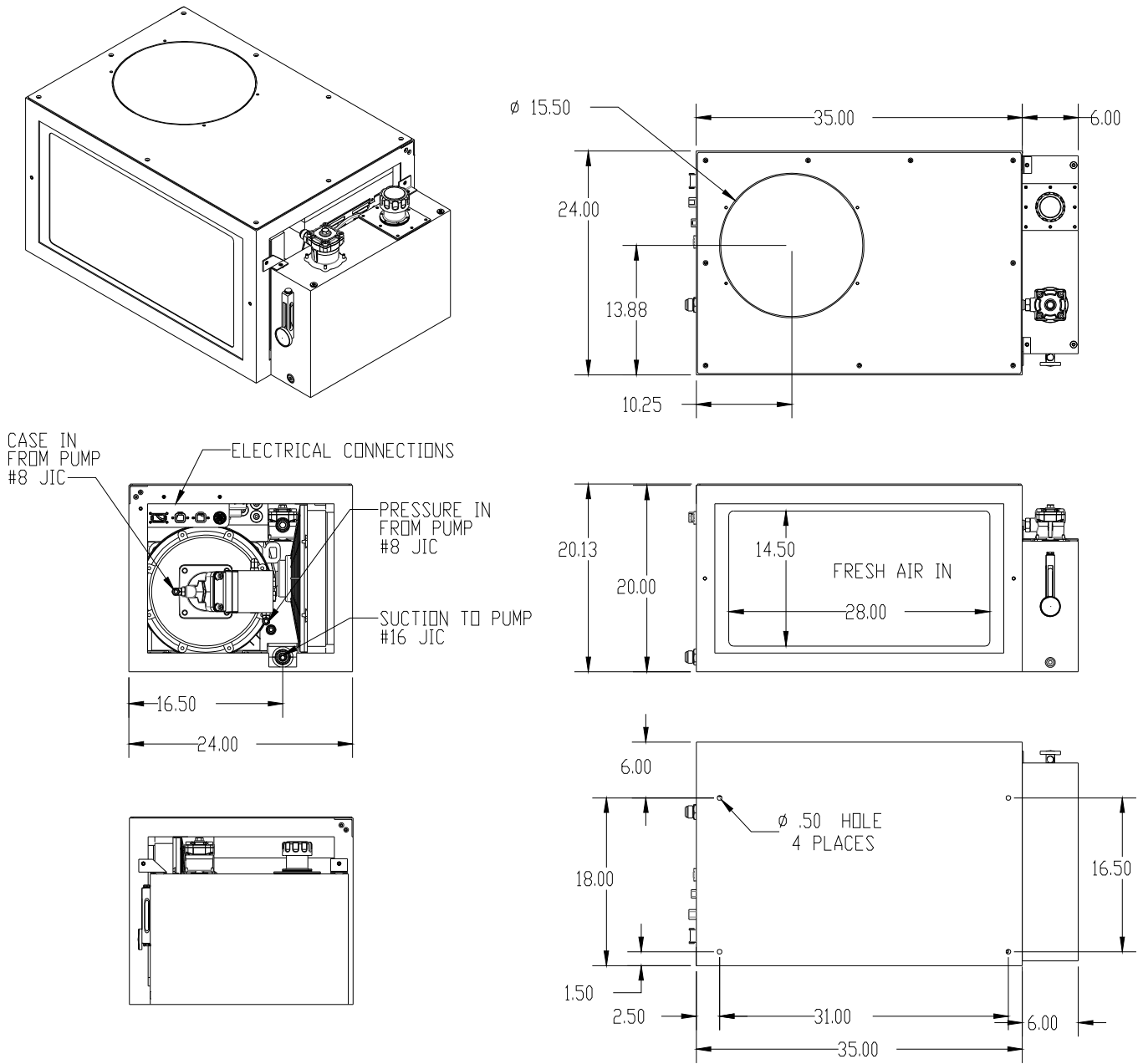
**Type:** Hydro Leduc Bent Axis Piston Motor  
**Displacement:** 32cc (10-20KW)  
 41cc (30KW)

# DIMENSION DRAWINGS

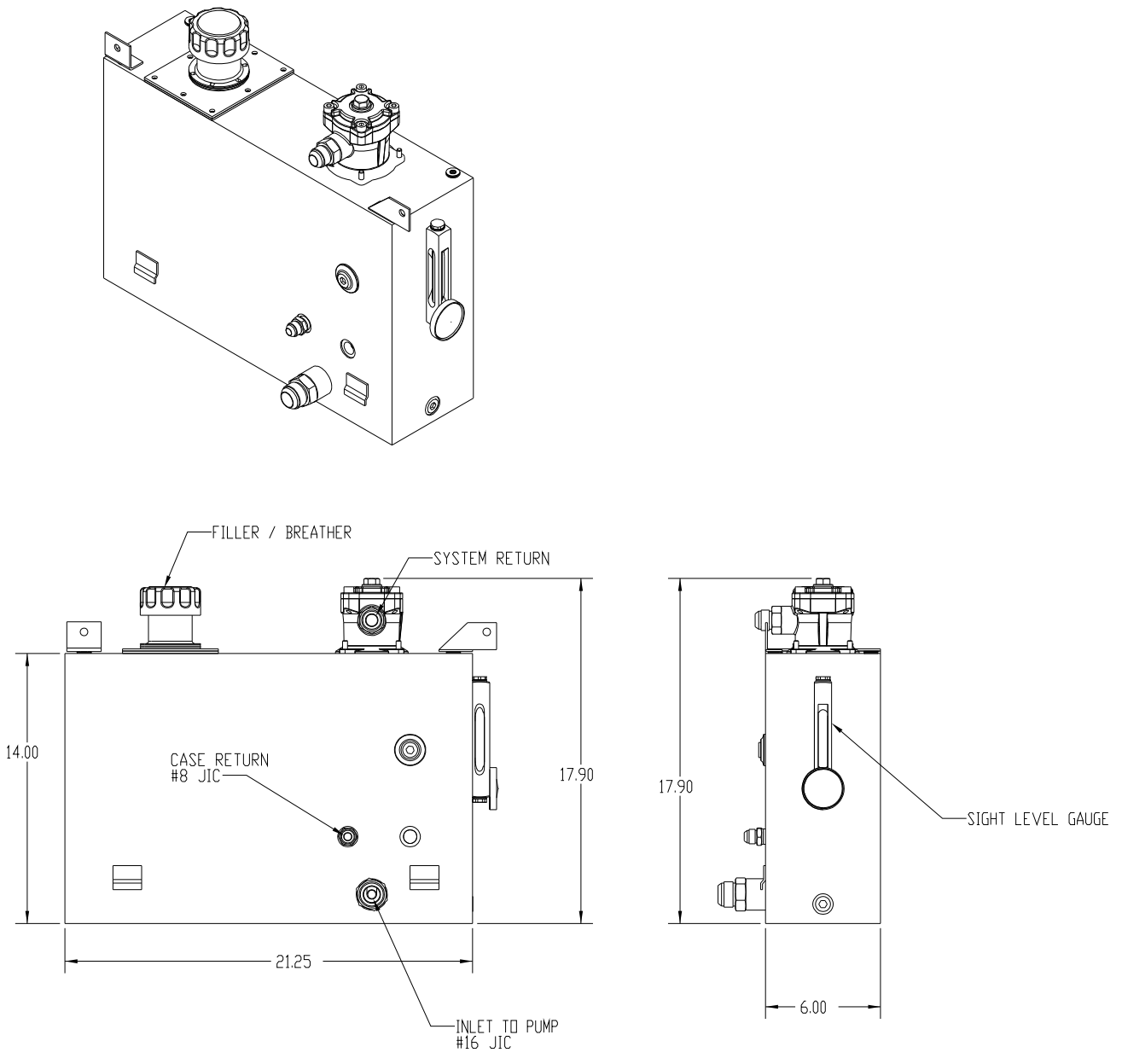
GENERATOR SHOWN WITH  
VERTICAL DRAFT TOP OPTION



**Figure 1: Generator Tray Dimension Drawing (MPC 10-20KW)**



**Figure 2: Generator Tray Dimension Drawing (MPC 30KW)**



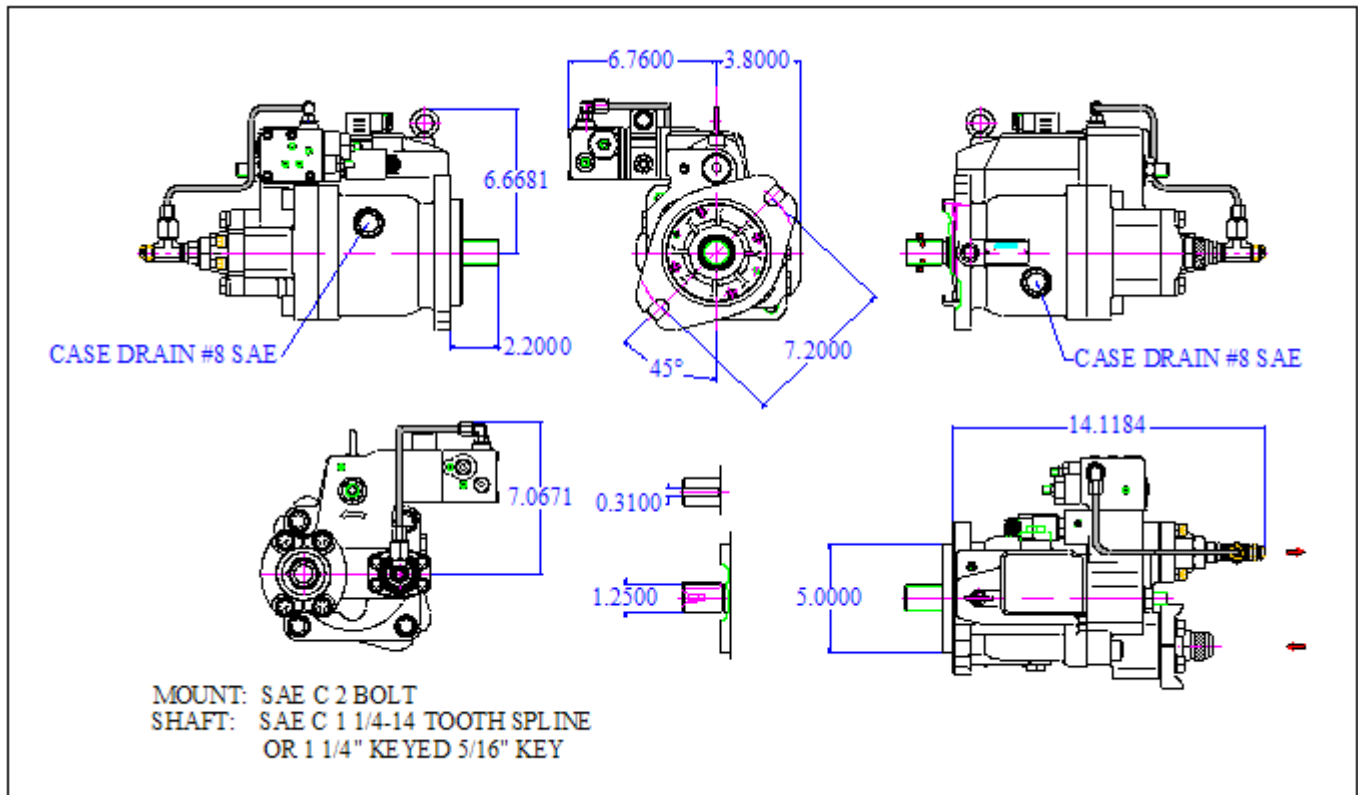
**Figure 3: Reservoir Dimension Drawing**

## HYDRAULIC PUMP INFORMATION

### 80CC KAWASAKI PUMP

<b>Min / Max Shaft Speed</b>	(10-20 KW MPC) (30 KW MPC)	900 / 3000 RPM † 1150 / 3000 RPM †
<b>Displacement</b>		80 CC
<b>Min / Max Temperature</b>		-4 / 204° F
<b>Pump Weight</b>		78 lbs
<b>Maximum Input Torque</b>		295 ft. lbs
<b>Pump Shaft</b>		SAE "C" Spline or Keyed
<b>Maximum Pressure</b>		5200PSI
<b>Rotation</b>		CW or CCW
<b>Maximum Vacuum</b>		10.0 in. Hg.

† Note: Consult Harrison factory for pump speeds above 3000 rpm.



**Figure 4: Kawasaki Pump Dimension**

*\*\*\* Other pumps are available. Consult Harrison factory for information.*

# INSTALLATION GUIDE

The hydraulic generator system must be installed properly to operate reliably, quietly, and most importantly, safely. Read the entire manual and option instructions before installation.

## INSTALLATION CLEANLINESS

### CAUTION!

**MAINTAIN OIL CLEANLINESS DURING INSTALLATION. DEBRIS IN A HYDRAULIC SYSTEM MAY DAMAGE INTERNAL COMPONENTS OR CAUSE THE PUMP COMPENSATOR TO STICK, RESULTING IN ERRATIC OPERATION.**

- Ensure the work area is free of dirt and always keep ports plugged until hoses are installed.
- Filter oil through a 10 micron (or better) absolute filter before using it in the generator. Even a new barrel of oil can contain contamination that is harmful to a hydraulic system.
- Thoroughly flush hoses before connecting. It is best to clean your hoses using an air gun like the one shown below. See the Accessories page in the Appendix for more information.



Figure 5: Air Gun Projectile Cleaner

## HYDRAULIC OIL REQUIREMENTS

Harrison Hydra-Gen, Ltd. recommends a premium anti-wear hydraulic oil to be used in the generator system. Dexron III **does not** fall in this category. Dexron is formulated to operate in transmissions and is an excellent fluid for them. We find that although our system will operate with Dexron, it is not the best selection. The weight of the oil is determined by the climate the system is operating in. Using an **AW46** will provide good protection in most year round US climate conditions.

A graph of ISO Oil Grades versus applicable fluid temperatures is shown below. The lowest allowed cold start temperature (at 4600 SUS) for each grade is shown as a triangle. The bar represents the ideal viscosity range for that fluid (80-170 SUS). The diamond at the top signifies the upper temperature limit of the fluid (at 60 SUS). Do not exceed this limit for a prolonged time period.

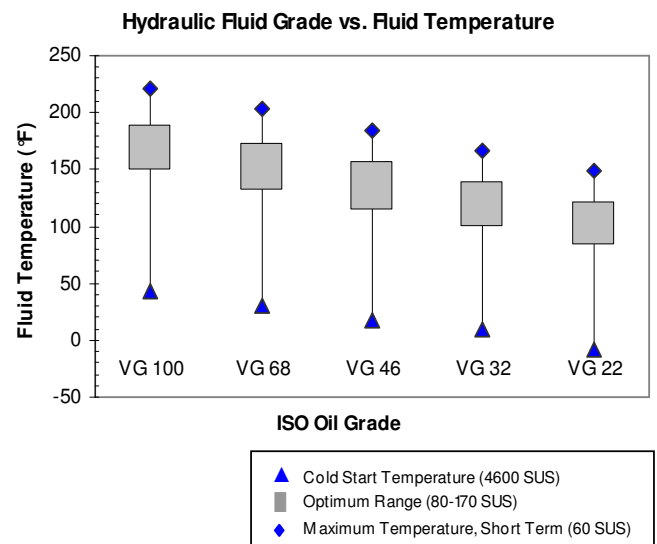


Figure 6: Hydraulic Fluid Selection Graph

The operating temperature of the fluid in the hydraulic generator system is maintained at 120°F to 180°F, depending on the ambient air temperature and



load. Fluids with a viscosity rating of less than 60 SUS at this temperature are not acceptable. For cold climates, the oil must not have a rating higher than 4600 SUS. Conditions that allow the fluid to drop in temperature causing the viscosity to be higher than 930 SUS will require warm up procedures before using the system. If there is some uncertainty about the oil that you are using, consult with the manufacturer or distributor of the oil.

Every oil mfg. offer oils that meet the needs of hydraulic systems. An example of good oil is **Mobile DTE-25** or equivalent.

## HYDRAULIC PUMP MOUNTING



### **CAUTION!**

**FRETTING OCCURS WHEN A MALE SPLINE SHAFT IS INSTALLED INTO A FEMALE SPLINE AND THE TEETH BECOME WORN OVER TIME. BEFORE INSTALLING THE PUMP INTO THE PTO, GREASE THE SPLINES WITH AN APPROVED SPLINE LUBRICANT.**

### **FRETTING**

During installation, ensure grease is applied to all the teeth and teeth roots of both the PTO and pump. Fill the valleys of the spline roots of both PTO and pump shaft. This allows extra lubricant to carry through the spline contact area by centrifugal force. While it can significantly prolong spline life, this procedure cannot guarantee to completely eliminate excessive wear. Chelsea supplies a packet of this grease with every PTO they sell and it is also available in a grease gun tube. For more information, see the Accessories page in the Appendix.

Maintaining this area requires removing the pump from the PTO, cleaning the splines of the old grease, drying the cleaner, reapplying new lube and re-installing the pump. This is not easy to do and is very time intensive. Some Chelsea PTOs, such as the

constant mesh series, have the option to install grease fitting which allows grease to be pumped into this area without removing the pump. Consult your PTO manufacturer for availability. We strongly suggest this option for constantly engaged PTOs since it greatly reduces maintenance time.

### **MAINTENANCE CONSIDERATIONS**

Even the best lubricant is eventually pushed out of the connection area by centrifugal force, temperature, and vibration. The time frame for maintenance depends on many operational and environmental factors, so a fixed time schedule is not practical. When the lubricating film is lost it must be replenished. Consult your PTO manufacturer for more information.

Shaft fretting is not a failure of the generator, pump or PTO. Fretting conditions are a result of torsion vibration generated by the engine. This vibration is transmitted through the transmission and PTO. Since the pump is the last member in the chain, the spline areas of the PTO and pump suffer the effect. This condition occurs primarily at low engine idle speeds. To avoid this condition and prolong shaft life, keep it well lubricated. Since this condition occurs at engine idle, Harrison recommends using a hot shift PTO instead of a constant PTO. With a constant PTO, the pump is always on when the engine is on. This subjects the pump and other components to unnecessary wear. Also, consider operating the generator at a high engine idle.

We understand that every application is different and is driven by your needs. If you require generator power at low engine idle and operation with a constant PTO, our generator will provide many years of reliable power if the maintenance requirements are met.

## PUMP MOUNTING LOCATIONS

Pump mounting varies with each application and pump used. Mounting options include mounting directly to the PTO or to the transmission. Ensure you are using the correct PTO ratio so the pump operates at the correct rpm.

### **CAUTION!**

**FAILURE TO PROPERLY ISOLATE THE PUMP FROM THE CHASSIS MAY RESULT IN UNWANTED NOISE AND/OR DAMAGE TO THE PUMP SHAFT.**

### PTO DIRECT MOUNTING

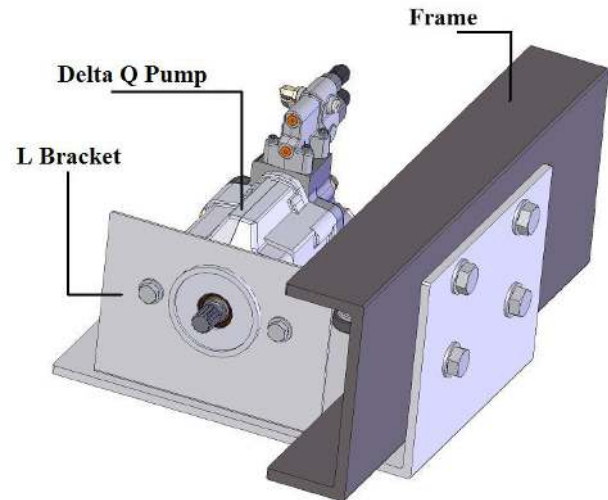
When mounting the pump directly to the PTO you **MUST** lubricate the pump and PTO splines. Failure to do this will cause premature spline failure (fretting).

Most PTOs limit the weight on the flange to 40 lbs. Most of our pumps weigh more than this limit. To avoid damage to the PTO, secure the rear of the pump to the vehicle's transmission case with a triangle brace. While the brace must not exceed 1/8" thick under the pump bolt, the remainder of the bracket should be sufficiently thick to support the pump. Torque the pump bolt and the transmission case bolts as specified in the transmission service manual.

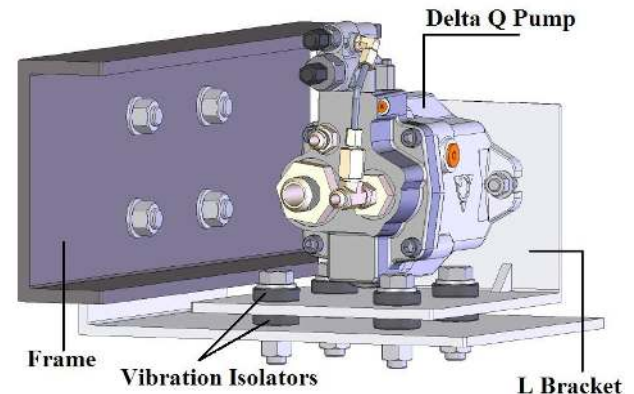
### TRANSMISSION MOUNTING

Before mounting the pump to the transmission, obtain approval from the manufacturer. Verify the extra weight does not exceed the recommended stress on the transmission. In most cases, a pump-mounting bracket can be built to fasten to the bolt pattern off the rear of the transmission.

In some cases there is no room for a direct mount and the pump will need to be mounted onto the chassis using an "L" bracket such as the one in the figure below. When driving the pump via drive shaft, design the "L" bracket with consideration of pump harmonics and the usage of vibration isolators.



**Figure 7: Pump Mounting L-Bracket Front View**



**Figure 8: Pump Mounting L-Bracket Rear View**

It is important to follow good driveline installation practices:

- Maintain drive shaft angularity within 5-8°.
- Maintain phase relationship between end yokes.
- Allow slip movement in shaft make up.
- Ensure shafts are parallel within 1.5°.

Proper installation techniques for the drive shaft, PTO, clutches, or other mechanical means of driving the hydraulic pump must be followed. Consult the factory or authorized distributor of the device for installation assistance.

## KEY POINTS

1. Always mount the pump with the case drain on top. Pump failure will occur if the case drain port is on the bottom of the pump. **Improperly installing the case drain will void the warranty.**
2. If used, ensure the soft start valve (mounted on pump) is wired to a time delay relay or is multiplexed so that the **soft start solenoid activates 3 seconds after the PTO** has been engaged. If there are any secondary or remote switches, be sure that they cannot be activated prior to 3 seconds of PTO engagement.
3. All PTO manufacturers require PTO engagement below 1000 rpm. High-speed engagement will cause catastrophic damage to the PTO and/or the pump. A high-speed lock out may be prudent.

Consult with your PTO manufacturer for more information.

4. Use sweeping 90° fittings whenever possible.

### **WARNING!**

**WITH THE NEW 2007 EMISSIONS, ENGINE EXHAUSTS ARE OPERATING HOTTER. IF OIL COMES IN CONTACT WITH THE EXHAUST, A FIRE COULD OCCUR.**

5. To help reduce heat radiation and to help protect the exhaust from oil in the event of a hydraulic leak such as hose failure, Harrison strongly recommends installing a heat shield around the exhaust.

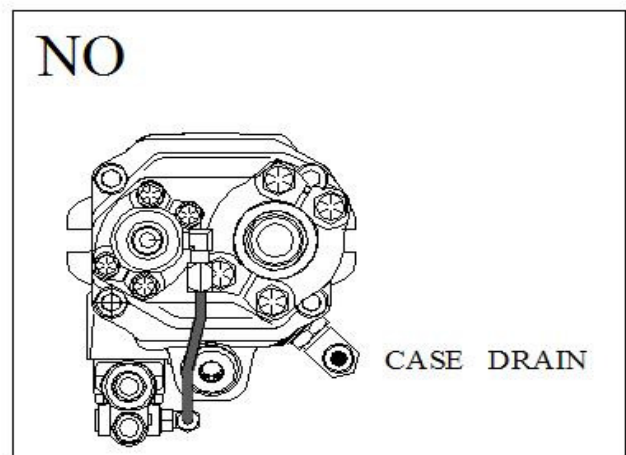
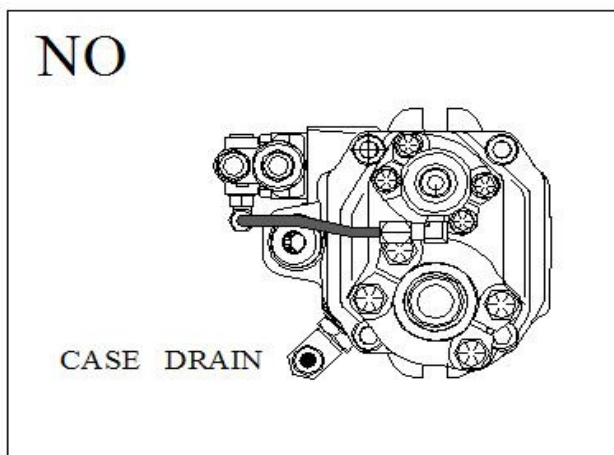
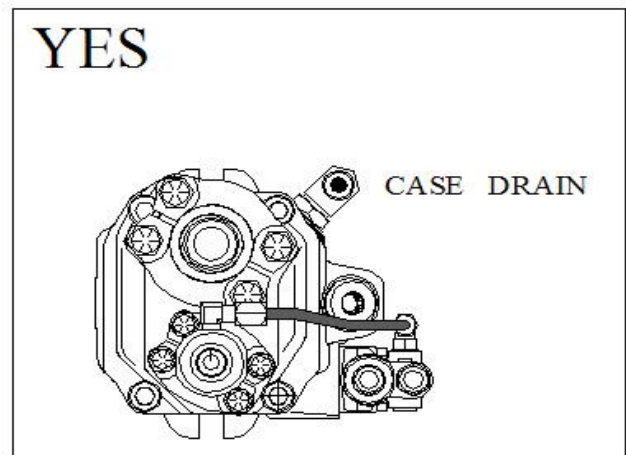
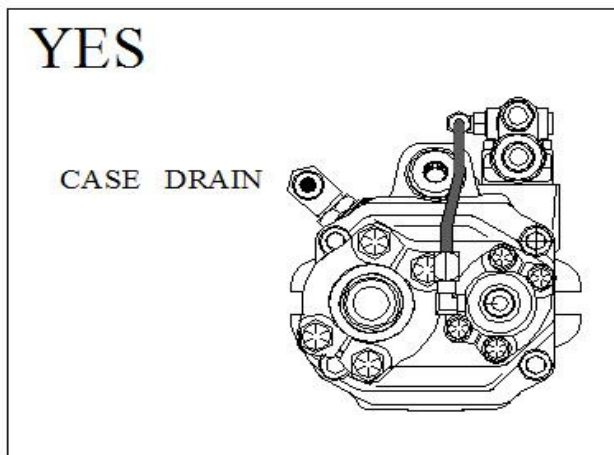


Figure 9: Pump Case Drain Orientation

## GENERATOR TRAY MOUNTING AND AIRFLOW

The generator tray is constructed of 11 gauge steel that has been powder coated for protection from the elements. When choosing a mounting location for the generator tray unit, take into account the following factors:

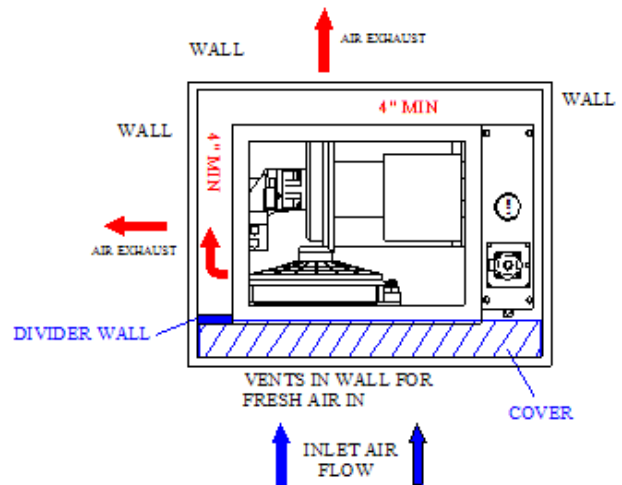
- Airflow and ventilation.
- Protection from debris and water
- Service and weight constraints

The most important factor to consider when mounting the tray unit is the air ventilation. The **minimum** distance between the nearest wall to both the intake and exhaust is 4 inches. Also, arrange the unit so that the exhaust air does not re-circulate into the inlet.

### CAUTION!

**SUPPLY THE GENERATOR TRAY WITH ENOUGH FRESH AIR AT THE INLET. ALSO, THE HOT EXHAUST AIR NEEDS AN ADEQUATE OUTLET SO IT DOES NOT CIRCULATE INTO THE INLET.**

The following figure shows an example of air flow around the generator tray. We offer an intake shroud for certain installations. If the system oil temperature exceeds 180°F, check the inlet and exhaust for restrictions. If the inlet air temperature is above 120°F, this may be an indication that the hot exhaust air is re-circulating into the intake and additional baffling is necessary.



**Figure 10: Generator Airflow**

Generally, all alternators cool the same way. Fresh air is pulled in one end of the rotor/stator assembly and exhausted out the other end. It is important to keep out road salt, dirt, snow, water, and other contaminants. Another consideration is high water crossings. Inspect the tray assembly on a regular basis. If any generator system is submerged in water, it will destroy the electrical components unless it is completely dried before use. Contact the Harrison factory for more information.

## HYDRAULIC RESERVOIR REMOTE MOUNTING

### CAUTION!

**ALWAYS MOUNT THE RESERVOIR AT LEAST 12 INCHES HIGHER THAN THE CENTERLINE OF THE PUMP TO ELIMINATE CAVITATION.**

Key considerations when remote mounting a reservoir include:

- Ease of access for replacing hydraulic fluid and filter, and checking the fluid level and temperature.
- Heat from external sources, such as adjacent motor or pump-house access holes.

## HYDRAULIC CONNECTIONS

### CAUTION!

**ENSURE THE PUMP CASE DRAIN IS ON THE TOP OR SIDE WHEN MOUNTING THE PUMP. FAILURE MAY OCCUR IF IT IS LOCATED ON THE BOTTOM.**

Harrison Hydraulic Solutions standard hose sizing is #16 hose for the pump suction inlet, #12 hose for the loop return, #8 hose for the pump pressure outlet, and #8 hose for the pump case, and #8 or #4 hose for the case return, depending on model. Hose sizes and ratings are included in the following installation section and are good for applications where hose lengths are less than 20 feet.

For hose lengths greater than 20 feet, we recommend hose sizes at least one (1) size larger than specified above. This is to ensure an adequate hydraulic fluid flow rate to the pump. Contact the Harrison factory at 1-800-723-3334 for assistance.

## HOSE SPECIFICATIONS

### Suction hose (#16) - Wire Inserted Suction Hose

Must be rated for suction

*Max Operating Pressure:* 60 PSI

*Vacuum Service (sizes 12 – 64):* 28 in./Hg.

*Approved Example:* SAE100R4

Route from the reservoir outlet to the pump inlet.

### Loop Return hose (#8 or #12) by model

*Max Operating Pressure:* 250 PSI

*Temperature Rating:* -40°F - +200°F

*Approved Examples:*

SAE100R3, SAE100R1A, and SAE100R1AT

Route from the generator tray to the filter housing.

### Pressure hose (#8)

*Max Operating Pressure:* 4000 PSI

*Temperature Rating:* -40°F - +200°F

*Approved Example:* SAE100R12

or

*Max Operating Pressure:* 5000 PSI

*Temperature Rating:* -40°F - +200°F

*Approved Example:* SAE100R13

Match hose to system pressure requirements. Route from the pump outlet to the generator tray pressure in port.

### Case and Case Return hoses (#8)

*Max Operating Pressure:* 250 PSI

*Temperature Rating:* -40°F - +200°F

*Approved Examples:*

SAE100R3, SAE100R1A, and SAE100R1AT

Route from the pump case to the generator tray case in port.

### CAUTION!

**DO NOT USE A PRESSURE HOSE THAT IS NOT RATED FOR VACUUM FOR THE SUCTION HOSE.**

The standard pump for our generator is rated with both a vacuum and pressure requirements. During normal operation, the suction hose experiences a maximum of 60 PSI; however, upon startup the pump will pull a vacuum. If a non-vacuum rated hose is used, its interior wall will collapse. Evidence of this is sustained cavitation of the pump during startup. Repeated sustained cavitations will damage the pump.

**SAE100R5 hose is not acceptable.** This type of hose does not carry enough vacuum rating in the sizes above #12. Verify the suction hose size during installation or service. Incorrect hose sizing may cause hydraulic pump failures, poor operation and may result in personal injury or equipment damage.

The SAE100R4 hose maximum working pressure for a band clamp or a bolted clamp (similar to a radiator hose clamp) is only 50 PSI. This type of clamp will not carry the required pressure rating; therefore, **a crimped hose end must be used.** All fittings are JIC 37° Flare.

See the hydraulic schematics on the following pages for hose routing. **It is important not to cross hoses during installation.** We recommend marking and capping/plugging hose ends **before** routing hoses. It is very easy to mix them up once they are routed in the vehicle.

## KEY POINTS

- Keep hose lengths as short as possible. If the hose length is 20ft or longer, increase the hose diameter. Contact the Harrison factory for a recommendation.
- Hose sizes and hose fittings must match.
- Always flush and blow out hoses before use.
- Mark and cap all hose ends before routing hoses.
- Hoses flex under pressure. Do not band them together tightly, pull them tight, or cut them too short.
- Never bend hoses beyond the manufacturer's recommended bend radius. Hoses will pinch if you exceed the bend radius of the hose, causing a restriction in the flow. Avoid short elbows. If a 90° fitting must be used, use a sweeping 90° instead of a short 90°.

## PLUMBING DIAGRAMS

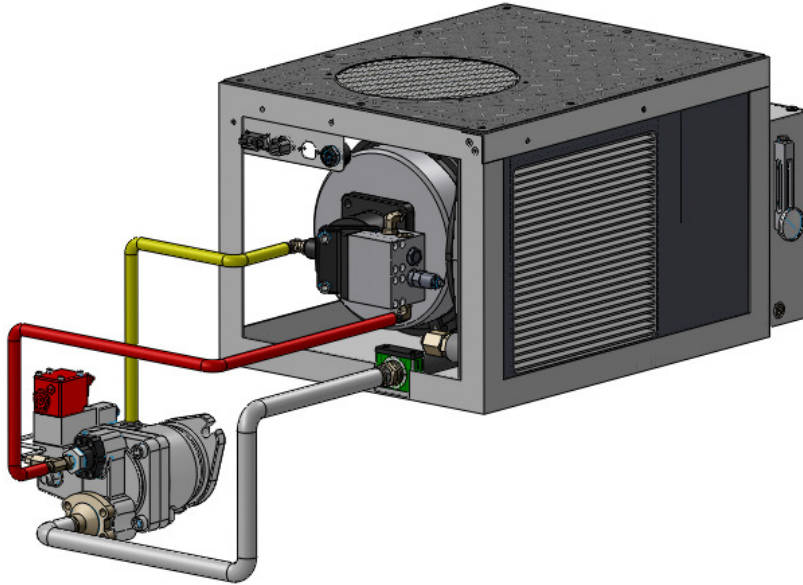


Figure 11: Attached Reservoir

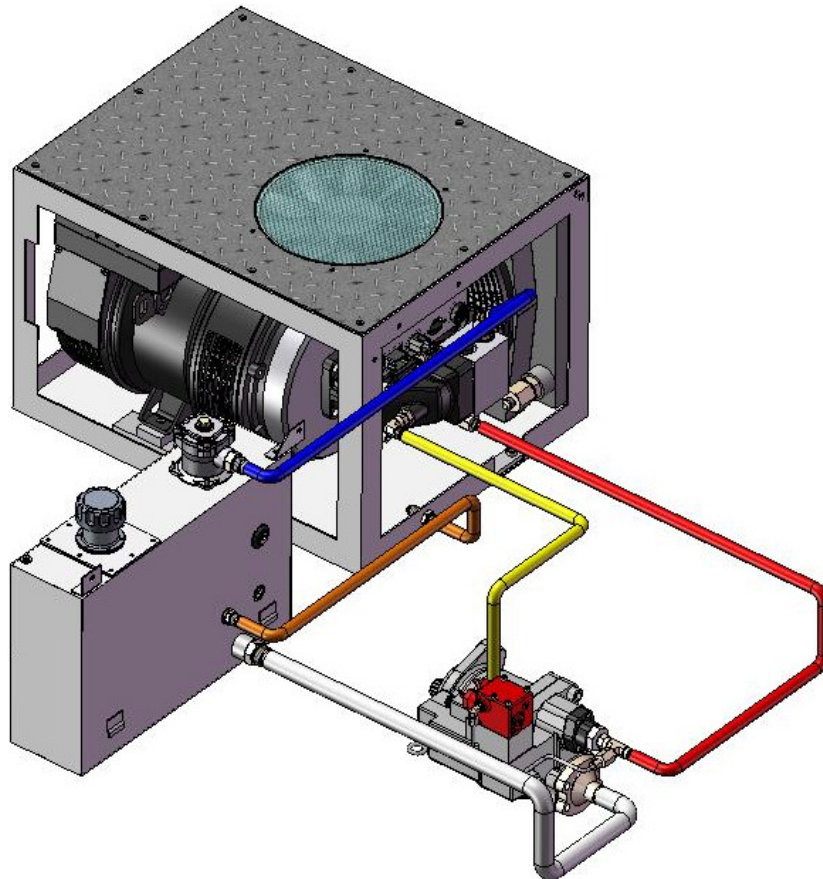
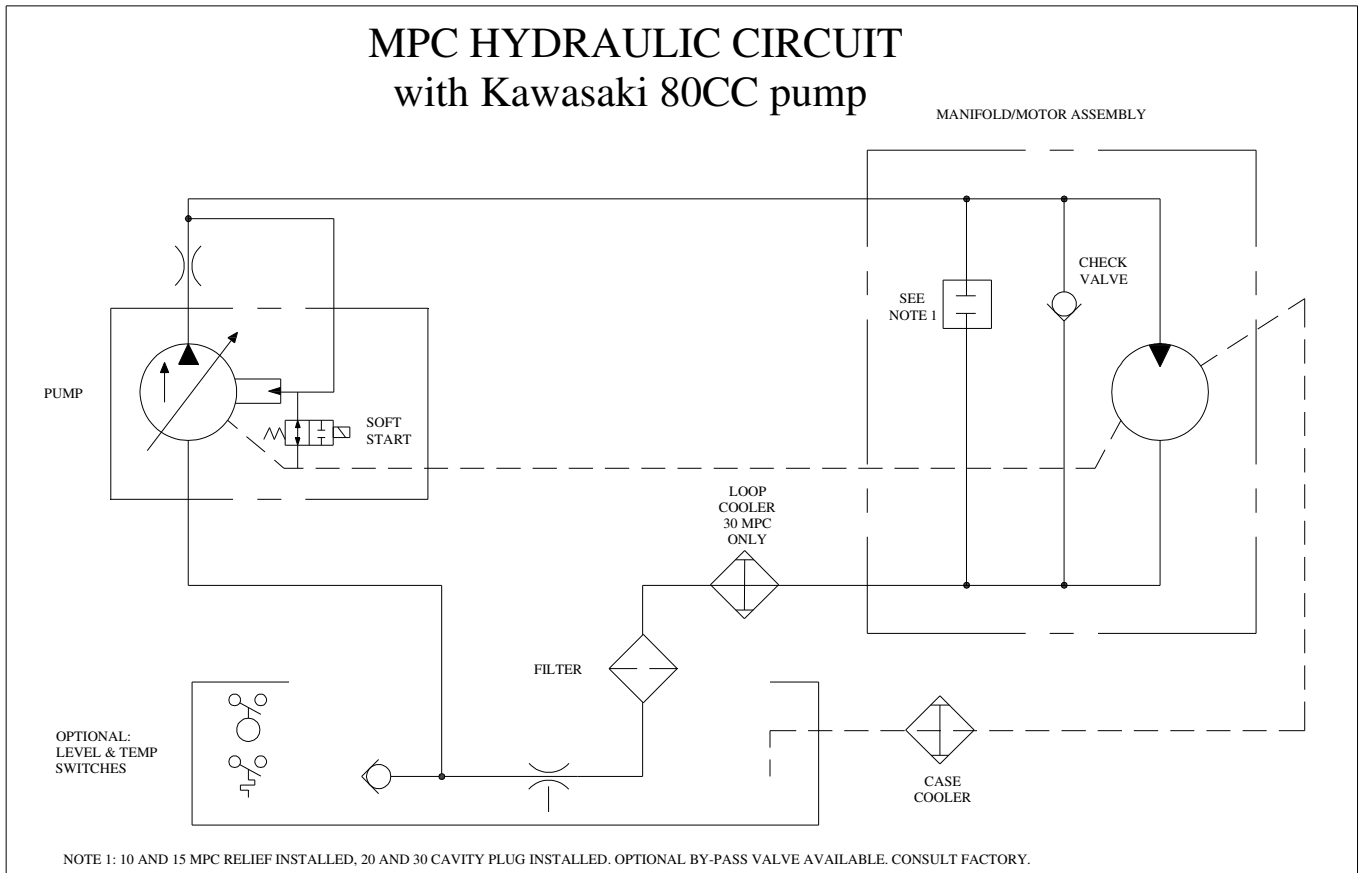


Figure 12: Detached Reservoir

# HYDRAULIC CIRCUIT DIAGRAM



**Figure 13: Hydraulic Circuit Diagram with Kawasaki 80cc Pump**



## DISPLAY METER MOUNTING

For Harrison Hydra-Gen generators that are shipped with the FRC generator display. The meter displays output voltage, frequency, and current. The key components packaged outside of the generator unit are:

- Display Meter
- Extension cable(s), 30 ft.

The display meter should be mounted where the generator operator can see the readout.

A cutout hole shown in the figure below is required for the display meter.

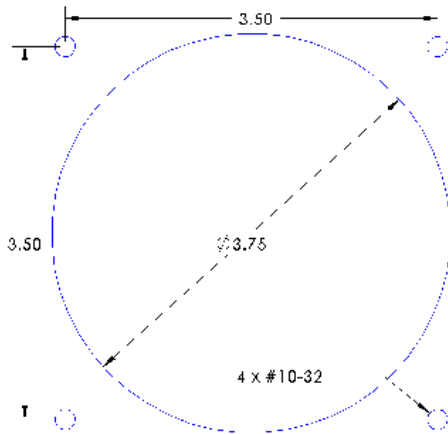


Figure 14: Display Meter Cutout Dimension

Follow these procedures to install the display meter:

1. Locate a suitable location for the display and cut the cutout hole and drill the 4 #10-32 mounting screw holes.
2. Route the 12-conductor extension cable from the generator to the meter. Plug the cable in to the generator supplied connector and the meter connector.

3. On most models a buzzer alarm is mounted in the generator tray. If not, a buzzer must be connected for the audible alarm. Refer to the Electrical Wiring Diagram at the end of this chapter for details.

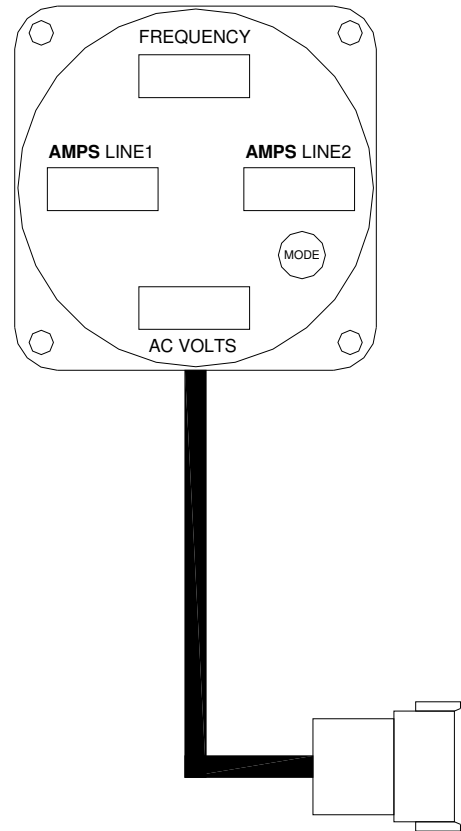


Figure 15: Display Meter

## ELECTRICAL CONNECTIONS

All wiring must meet applicable local, state, and federal electrical codes. Accordingly, have a qualified electrician install and inspect the wiring. Mount switches and controls securely to prevent damage from vibration and road shock. All switches must be vibration proof to prevent accidental opening and closing of circuits while the vehicle is in motion.

**⚠ WARNING!**

**EXHAUST GAS IS DEADLY! SEAL ALL WIRE OPENINGS IN THE VEHICLE INTERIOR TO KEEP OUT EXHAUST GAS.**

The generator system output conductors must be rated no less than 115% of the nameplate current rating of the generator system. The factory supplied conductor insulation is rated at 90°C. Wires connected to the generator must meet or exceed this insulation rating (See National Electrical Code, NFPA 70). State and local codes specify different grounding requirements for mobile vehicles with electric generator systems. These specific codes must be followed in order to ensure personal protection.

**⚠ WARNING!**

**FAULTY ELECTRICAL GROUNDING CAN LEAD TO FIRE OR ELECTROCUTION, RESULTING IN SEVERE PERSONAL INJURY OR DEATH. GROUNDING MUST BE DONE IN ACCORDANCE WITH APPLICABLE CODES.**

Generators mounted permanently on a mobile vehicle must be grounded securely to the vehicle frame. In addition, the **neutral conductor of the generator output must be grounded at the generator only.** Remove any grounding tabs or connectors that may be in the meter panels or distribution panels. This will avoid problems with personnel safety and Ground Fault (GFCI) devices.

The 4 generator AC output leads are visibly marked. Connect the leads as shown in the electrical diagram on the following page. All standard units are wired 120/240 VAC; however, generators can be reconnected for straight 120 VAC. **Contact Harrison factory for instructions.**

	CONNECTION
4-Wire S.O Cord	Generator to Breaker:
	Green – Ground
	White – Neutral
	Red – Leg 2
	Black – Leg 1
4-Wire Power Cable (Connector A)	Power Input:
	Green – 12Vdc (+)
	Red – 12Vdc (+)
	Black – Ground (-)
	Yellow – 12Vdc (+) ON/OFF
2-Wire (30KW Only) Power Cable (Connector B)	Power Input:
	Red – 12Vdc (+)
	Black – Ground (-)

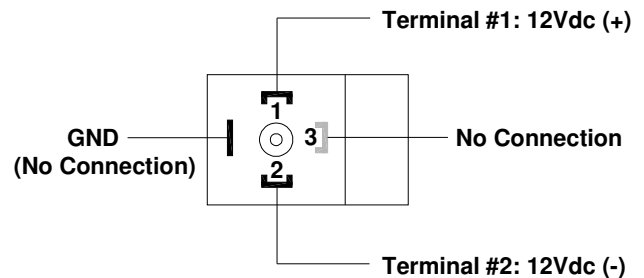
**Table 2: Summary of Electrical Connections**

**SOFT START SOLENOID WIRING**

Pump equipped with a Soft Start valve requires a time delay relay with a minimum of three seconds.

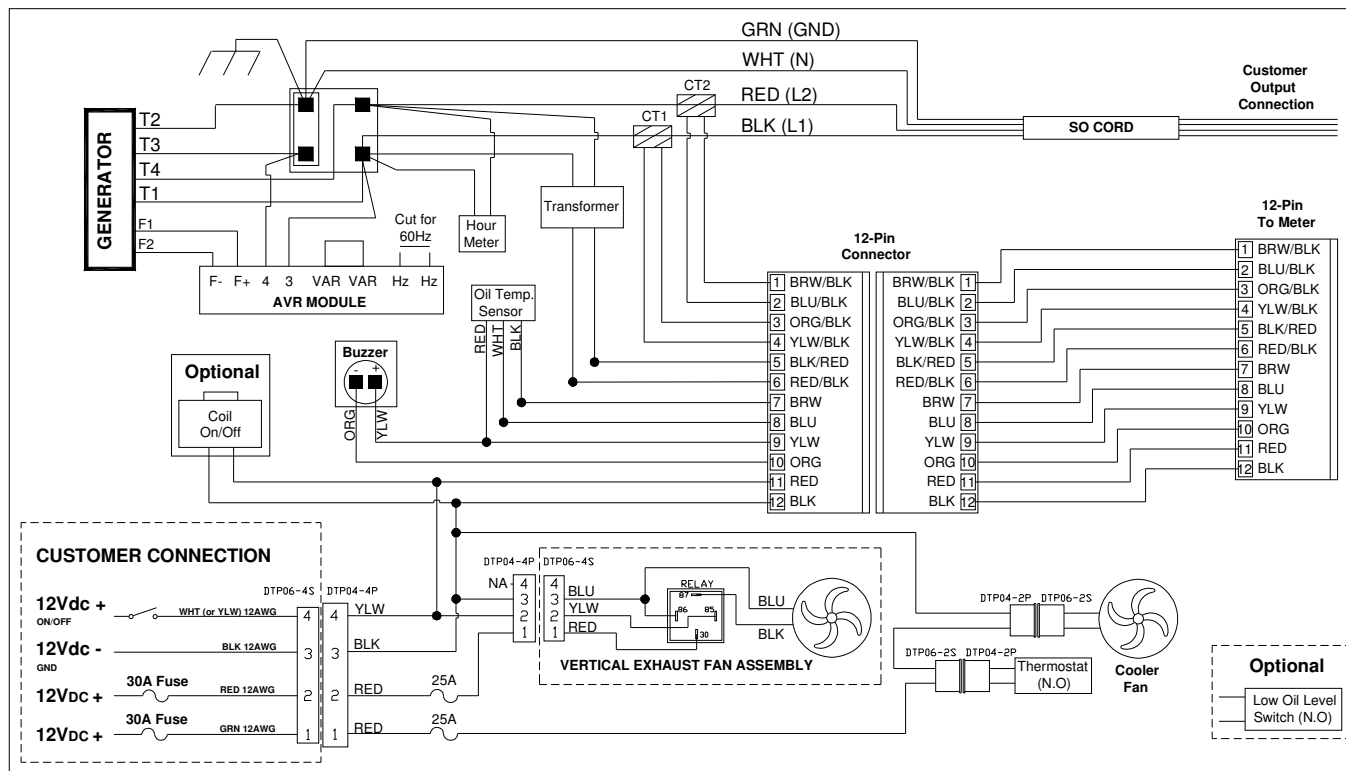
The soft start valve of the Kawasaki pump is mounted under the pump control. It comes with a 12Vdc coil and a DIN connector. Be sure the soft start valve is wired to a time delay relay or multiplexer so that the soft start solenoid activates three seconds (minimum) **after the PTO has engaged.** If there are any secondary switches, be sure that the switches cannot be activated prior to the three seconds of the PTO engagement.

The DIN connector has four connection terminals, labeled 1, 2, 3 and GND. Wire 12Vdc positive (+) to terminal 1, and 12Vdc negative (-) to terminal 2. **No Connections at terminals 3 and GND.**

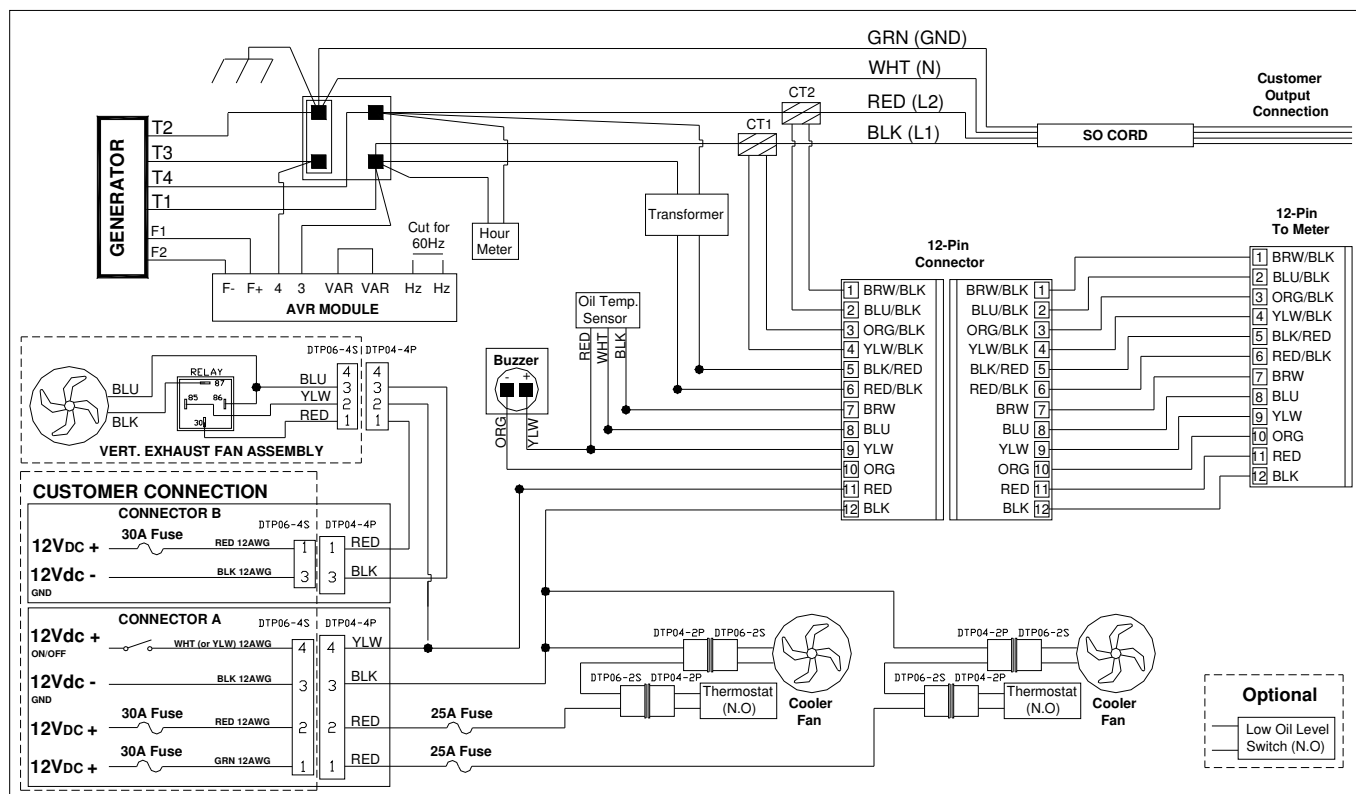


**Figure 16: Solenoid DIN Connector Connection**

# ELECTRICAL CIRCUIT DIAGRAM



**Figure 17: 10-20KW MPC Electrical Circuit Diagram for 120/240 1ph**



**Figure 18: 30KW MPC Electrical Circuit Diagram for 120/240 1ph**

# OPERATOR'S GUIDE

## BEFORE STARTING

Perform the applicable pre-operational service checks presented in this section before starting the system, after installation, or after major repairs or fluid and filter changes. Anytime the hydraulic system has been opened for repairs the fill and bleed sequence **must** be followed.

## FILL AND BLEED SEQUENCE

### CAUTION!

**CONTAMINATED OIL CAN SEVERELY DAMAGE A HYDRAULIC SYSTEM.**

Always use filtered hydraulic fluid (ISO 4406 or better) when filling the reservoir. Contaminated fluid can cause improper system operation and result in excessive wear of system components. Do not transfer fluid from its shipping container into the generator reservoir. Transfer oil from the shipping container through a filter cart with a minimum of a 10 micron filter. If a filter cart is not available use a filter cloth in a clean funnel. Check the fluid level of the reservoir and do not attempt to operate with a partially filled system.

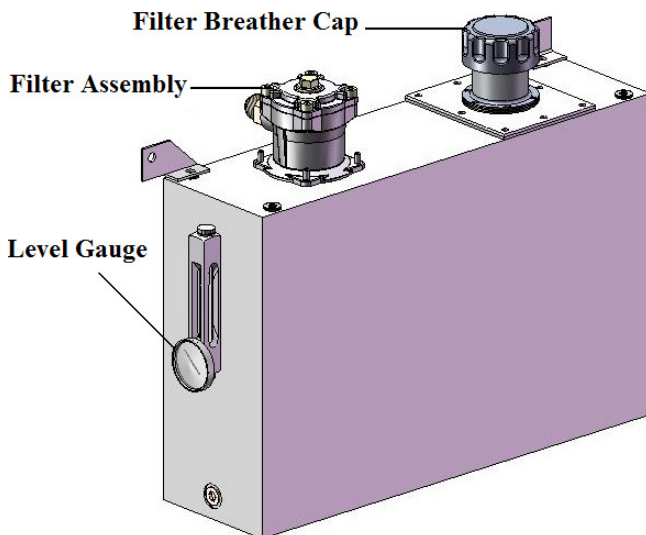


Figure 19: Hydraulic Fluid Reservoir

1. Ensure all loads are turned off and the main line circuit breaker is in the OFF position.
2. Transfer the filtered oil into the reservoir using a clean funnel. Fill the reservoir to the full mark on the sight glass. **Do not overfill!**
3. Fill the pump case with filtered oil.
4. Loosen the hydraulic hose connections at the pump inlet, pump case drain, and pressure hose. One turn should be enough.
5. If there is no free-flow of oil at the pump, pressurize the reservoir (maximum pressure 5 PSI) to force oil throughout the system until there is oil at all three hose connection points on the pump end.
6. Re-tighten all hose connections and wipe dry. Refill the reservoir with filtered oil to the full line. Cap the reservoir.
7. Turn the generator ON, engage the PTO (if equipped) and turn over the engine for a few seconds, if possible, without starting it.
8. Check oil level and fill accordingly.
9. Repeat steps 7 and 8 until the oil levels stabilize.
10. Start the engine and let the engine warm up until normal idle speed is obtained. Listen for pump noise. If a grinding noise (pump cavitations) is detected, shut the generator down and repeat steps 7 and 8.

### CAUTION!

**SUSTAINED CAVITATION WILL DESTROY THE PUMP. PURGE ALL AIR BEFORE CONTINUING.**

11. Continue running the engine at a low idle, check the total hydraulic system for leaks. If a leak is found, tighten the fitting and wipe dry. Do not over torque the flare fittings. Consult your fitting and hose supplier for the correct torque values. If

a leak persists, turn off the system and check the condition of the mating flare. If the flare is deformed or damaged, replace it and begin the bleeding process from the beginning.

12. Increase engine speed to the operating rpm. Let the system run without load for 10 to 15 minutes to allow trapped air to escape. Top-off the reservoir to the full mark with filtered oil.
13. Check the generator output and verify correct voltage and frequency readings. If readings are incorrect refer to the Frequency Adjustment section.
14. If the frequency or voltage is unstable, the system may still have a small amount of air trapped inside. Lower the engine speed to idle, and let the system run for another 10 to 15 minutes without load. Increase the engine to operating rpm and verify the voltage and frequency readings. Repeat this step as necessary in order to obtain stability in the system.
15. Run a final test for leaks with the engine running at operating RPM and full load on the generator system.

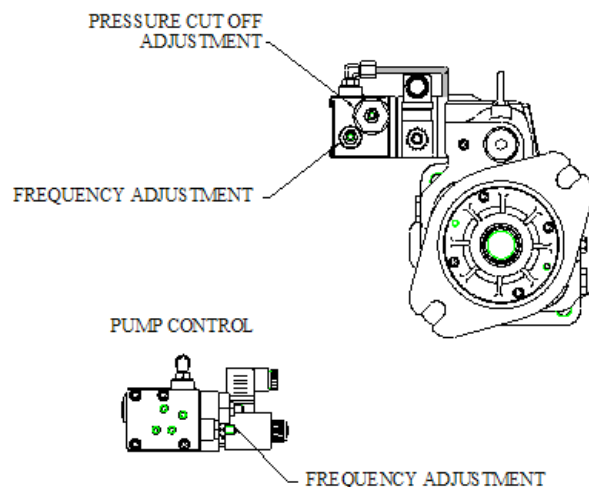
## FREQUENCY ADJUSTMENT

The frequency (Hertz) is an indication of the hydraulic pump flow.

1. Turn OFF the main line circuit breaker and remove any loads on the generator.
2. Start the vehicle's engine.
3. Engage the PTO.
4. Set the vehicle's engine rpm at high idle and let the hydraulic oil temperature warm up to a minimum of 100°F.
5. Turn the generator ON and check the frequency on the display module. If frequency is too low or too high, proceed to the next step.

### CAUTION!

**BEFORE PROCEEDING, TURN OFF THE LOAD ON THE GENERATOR SYSTEM AND VERIFY THAT THE PUMP IS WITHIN THE RPM OPERATING PARAMETERS.**



**Figure 20: Kawasaki Pump Control**

6. At the Pump Control, loosen the frequency adjustment jam nut with a wrench.
7. While holding the jam nut with the wrench (to keep it from turning), use an Allen wrench and turn the adjustment screw. Turn the adjusting screw **clockwise to increase** the frequency and **counterclockwise to decrease** the frequency.
8. When the frequency has been adjusted satisfactorily, hold the adjusting screw and tighten the jam nut.
9. Re-apply the load to the generator and verify that the frequency remains within the parameters.

If frequency is not stable or falls more than 3 hertz, air or contamination may be trapped in the pump spool valve. To flush the compensator, remove the spool valve. Run the system for 2 to 3 minutes. Re-install the spool and re-check the frequency.

## **NORMAL OPERATION**

Before operation of the system, always check the fluid level in the reservoir. Keep the generator system, cooling surfaces, and cooler fins clean. Store the hydraulic oil in dust-tight containers. Change the oil as frequently as necessary. The normal fluid and filter change interval is 250 hours of operation or one year of service, whichever comes first.

After installation and initial startup, follow the steps below to operate the system:

### TURNING SYSTEM ON

1. Start the vehicle's engine.
2. Engage PTO.
3. Turn on the generator.
4. Set engine to operating rpm.
5. Check voltage for proper output.
6. Set all circuit breakers to the "ON" position.
7. Apply load to the generator.

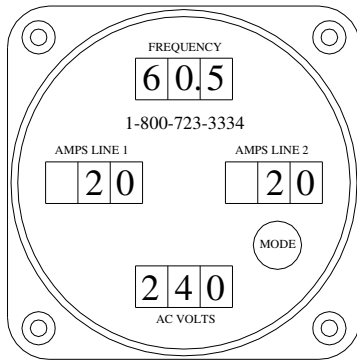
### TURNING SYSTEM OFF

1. Remove all loads from the generator.
2. Set all circuit breakers to the "OFF" position.
3. Turn off the generator.
4. Return engine speed to idle.
5. Disengage the PTO.

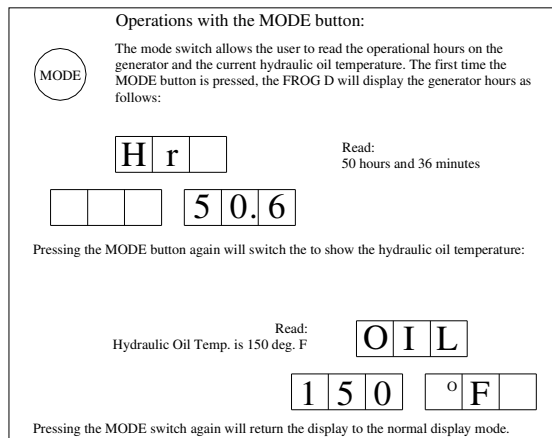
All operators of the vehicle should become familiar with the procedure for starting and stopping the generator system.

## DISPLAY MODULE

The FRC generator display module is designed to display AC generator data per NFPA 1901. Integrated warnings can alert the operator if a critical condition needs an appropriate action.



**Figure 21: Display Meter Module**



**Figure 22: Display Mode Button**

### Excessive Current Warning

When the generator is operating outside the range of its rated capacity, the AMP 1 and AMP 2 display will start to flash. The audible buzzer must be connected for the audible warning.

### Voltage Out-of-Range Warning

If the output voltage is below 100/200 VAC or above 130/270 VAC, the voltage readout will begin to flash. This will give the operator an indication that the generator output falls outside the safe operating level. There is no audible alarm for the voltage out of range warning.

### Hot Oil Temperature Warning

This warning will be activated if the oil temperature rises above 170°F, ± 5°F. The frequency readout will flash OIL to warn the operator and the audible alarm will also be activated.

## MAINTENANCE

Harrison hydraulic generator requires very little routine maintenance, which consists primarily of changing the oil, the filter, and performing a visual inspection of the generator tray. With a little maintenance and a proper installation, the system should operate trouble free for many years.



### **WARNING!**

**ACCIDENTAL STARTING OF THE GENERATOR DURING MAINTENANCE CAN CAUSE SEVERE PERSONAL INJURY OR DEATH!**

The hydraulic fluid and the filter should be changed every 250 hours or 12 months, whichever occurs first. Use a 10 micron absolute filtering system or better to clean the oil before adding it to the reservoir. Refer to the Installation section for oil selection recommendations. Refer to the Appendix for the replacement filter element. If the oil appears discolored, smells burnt, or feels abrasive to the touch, it indicates a system problem and steps should be taken to diagnose it.

Visually inspect the electrical wiring for corrosion and loose or bad connections.

Visually inspect the generator for debris or greasy soil build-up. This can impede airflow and cause premature generator failure.

Blow out the heat exchanger fins and the inside of the alternator with an air hose. **Do not use water to clean the inside of the alternator.**

If the alternator has been submerged in water, the windings **must** be dried before use. Immersion in

salt water requires cleaning of the generator and possibly re-coating with epoxy before use.

Check the fittings for loose connections and leaks. Inspect hoses for any bulges, chaffing, and damages. Replace immediately if defects are found.

Check the pump for securely mounting to the PTO or the drive shaft. Check for leaks from the fittings and the front seal. A leak at the front seal may indicate bad alignment or the need for vibration isolators. If a leak at the front seal is detected and corrected early, it can eliminate expensive repairs down the road.

If the pump is directly mounted to the PTO, the splines on the shaft and PTO **must** be properly greased and maintained. Read the caution on fretting under Maintenance Considerations in the Specifications and Installation Guide.

It is good to set up a weekly inspection of the generator. Things to look at would be

- Fluid level and condition
- Filler Breather is clean
- Hoses for leaks and condition
- Cooler is clear and free of dirt and debris
- Hour meter is operating





<b>ACCESSORIES</b>
--------------------

<b>Description</b>	<b>Part Number</b>	<b>Supplier</b>	<b>Phone Number</b>
Air gun hose cleaning system	UC-EL-1-1/4"	Ultra Clean Technologies	(800) 791-9111
Spline lubricant, grease gun tube	379831	Chelsea	(662) 895-1101
Oil Reservoir Filter Element	WO206-2200	Harrison	(800) 723-3334

<b>GENERATOR DISPLAY METER KIT</b>
------------------------------------

**FRC Package**  
**Harrison Hydra-gen Part #FR800-4812**

The FRC meter kit consists of the following components:

<b>Qty</b>	<b>Description</b>
1	Display Unit
1	Alarm Buzzer
1	Transformer
1	Oil Temperature Sensor
2	Current Transformer