



Your fleet is idling all day and all night to keep vital equipment protected: HVAC, interior/exterior lighting, communications equipment, electrical systems; including batteries, chargers, life-support systems, and more.

The Harrison *hPower* Idle Control System provides power for all your AC and DC requirements, while satisfying idle mitigation regulations. It seamlessly integrates with the apparatus chassis drivetrain system and electrical system.



Designed to alleviate the expenses and complications that come from constantly running an engine, use of the Harrison *hPower* Idle Control System results in less risk to the environment and personal health; a win-win for your entire fleet.

*"Clean, Reliable, Mobile Power;  
NOW available with the  
ENGINE ON or ENGINE OFF!"*



## Benefits of *hPower*

- Extends the life of the Chassis
- Reduces DPF regenerations
- Reduces fuel consumption
- Simplified installation
- Reduces NOx output
- May qualify for federal incentives

## Included parts

- Environmentally protected enclosure
- (1) Battery Monitoring System
- (1) Battery charger
- (2) lithium iron phosphate batteries
- (1) External display

## Performance specifications

- 275 Ah / 3.3 kWh
- Charging options
  - ✓ Shore Power
  - ✓ Alternator
  - ✓ Inverter
  - ✓ Harrison Generator

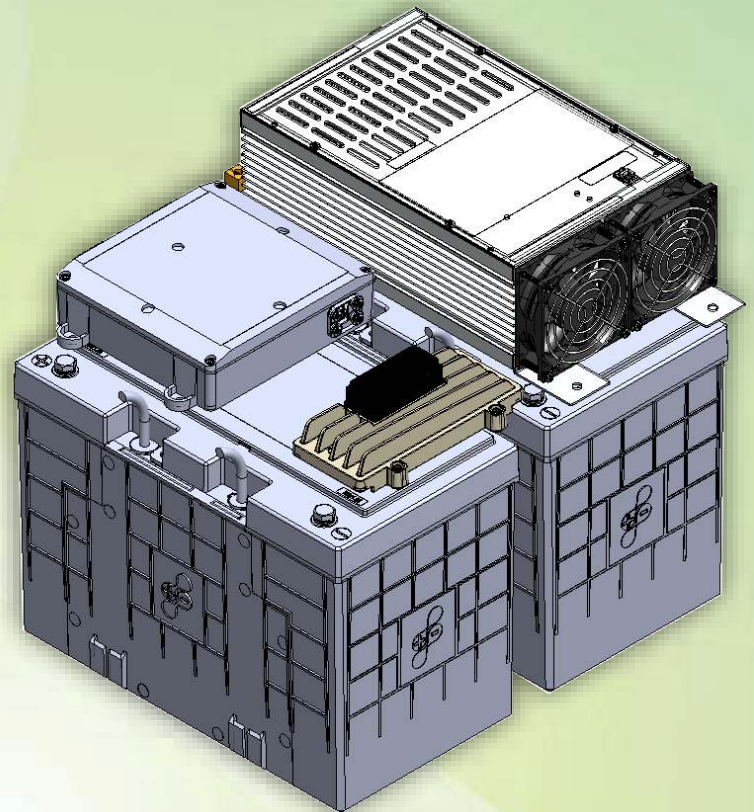

## Physical information

- Dimensions 17.5 W x 24.0 D x 15.0 H
- Weight: 152 lbs
- Connections:
  - ✓ CAN Bus
  - ✓ OEM Input
  - ✓ 12 VDC output



Harrison Hydra-Gen ®  
14233 West Road | Houston, TX 77041  
T: 800.723.3334 | O: 281.807.4420 | F: 281.807.4815  
sales@harrisonhydragen.org | www.harrisonhydragen.com



Rev V1  
10/21/19

*quality, service & dependability . . . guaranteed*